

FORD F-150 Lightning 2022 ->

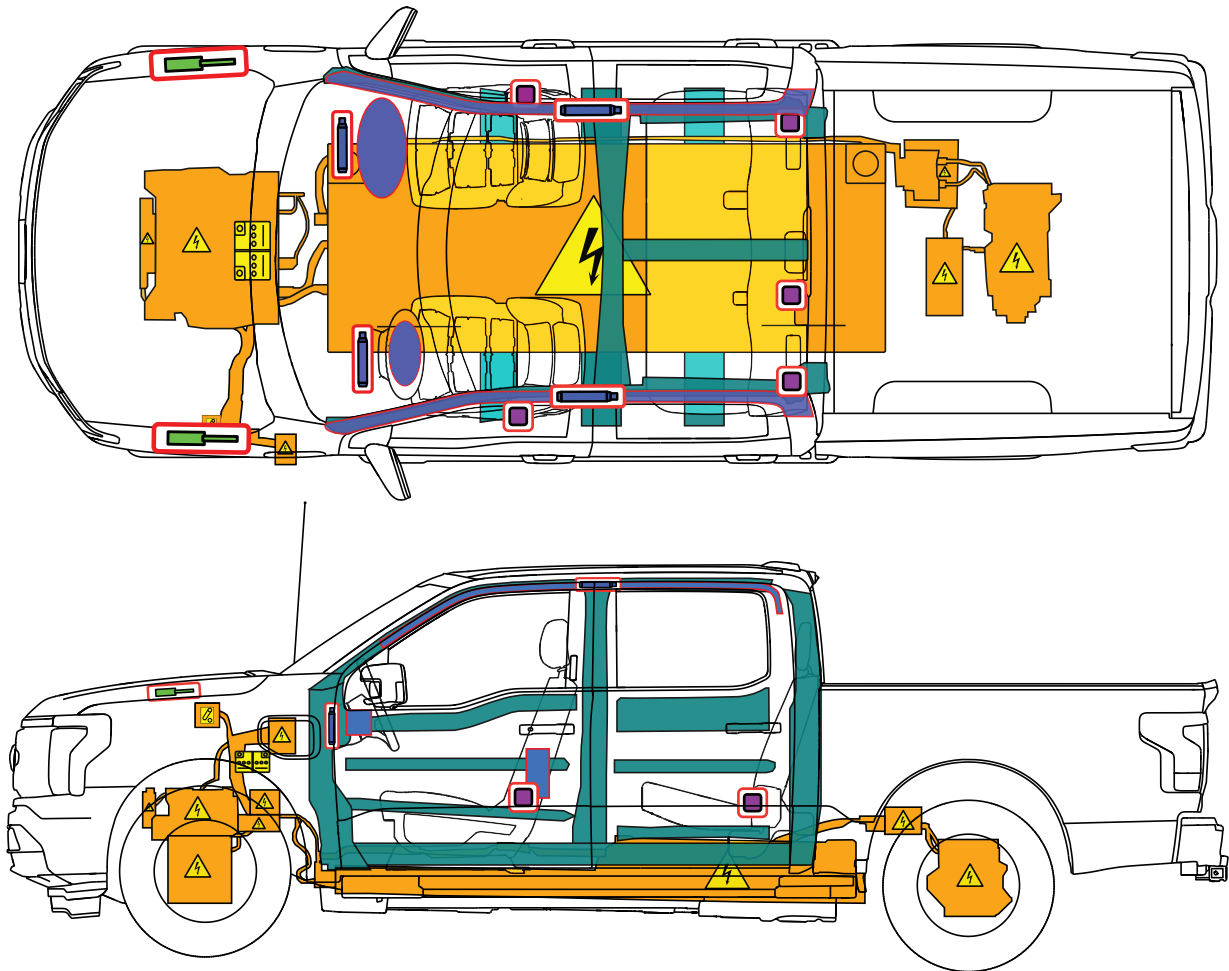

Legend

	Airbag		Structural Reinforcements		Control unit		High-voltage battery		High-voltage disconnection point
	Gas generator		Gas filled spring device		Battery		High-voltage wire / components		Fuel tank Gasoline
	Seat belt tensioner								



1. Identification / recognition

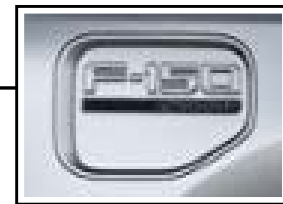

1. Vehicle Identification Number (VIN)
2. Charging port and Lightning badging on tailgate.

Vehicle Identification Number (VIN) Layout

The 8th position of the VIN identifies the vehicle's engine type as electric.

2022-2023 Model Year Vehicles:

- L - BEV (Duel Electric Motor), (Standard Battery #1)
- V - BEV (Duel Electric Motor), (Extended Range Battery #2)

Sample VIN

BEV - 1FT6W1EV2NWX01689

2024 Model Year Vehicles

- 7 - Duel Electric Motor, Extended Range Battery #4 - Single onboard charging
- K - Duel Electric Motor, Standard Battery #1
- M - Duel Electric Motor, Extended Range Battery #2 - Dual onboard charging
- S - Duel Electric Motor, LFP Battery #3

Sample VIN

BEV - 1FTVW3LK6RWG02995



2. Immobilization / stabilization / lifting

IMMOBILIZATION

1. Position Wheel And Tire Chocks

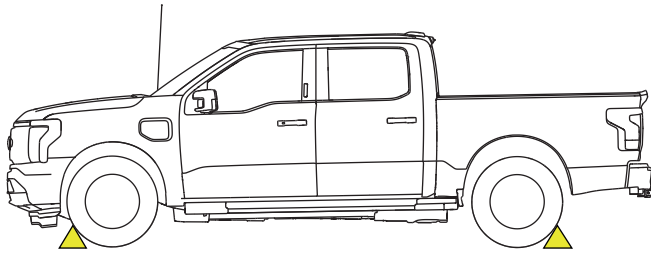

2. Put vehicle into Park position (1)
Ensure parking brake is engaged (2)



STABILIZATION / LIFTING

VEHICLES WITH AIR DEFLECTOR TYPE 1:

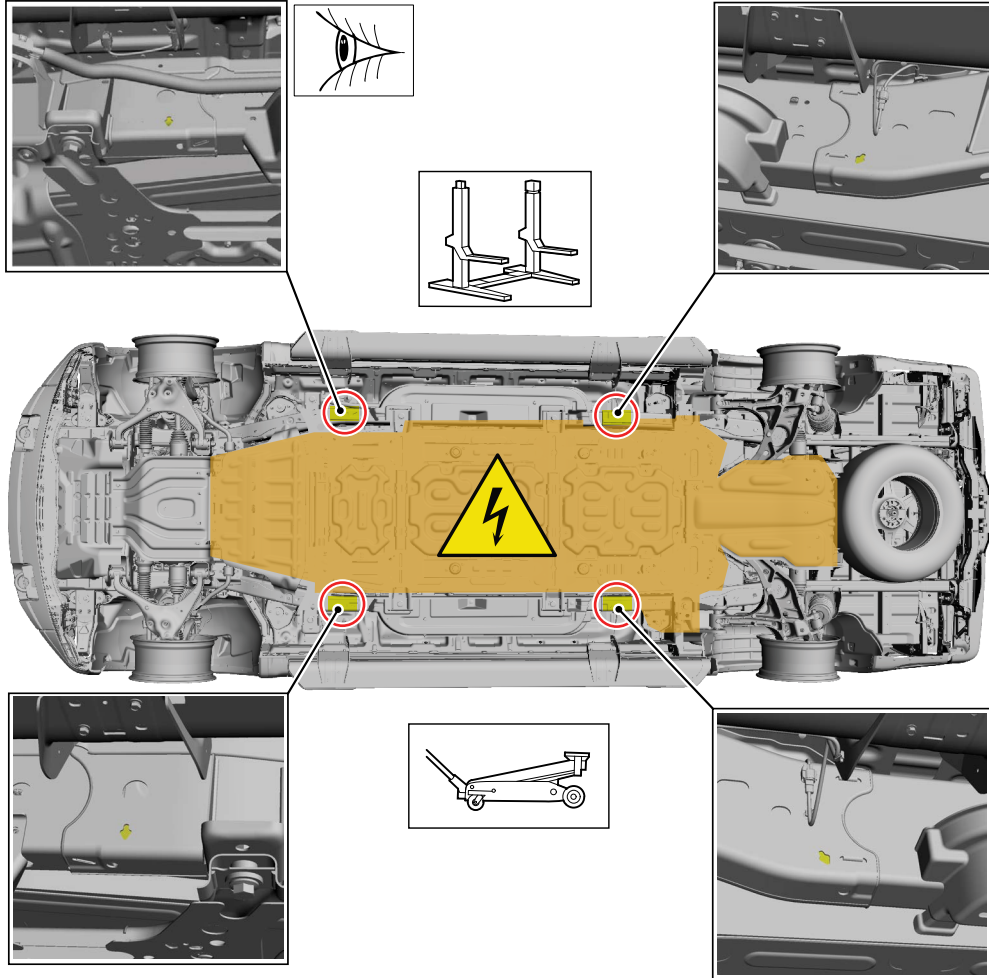

STABILIZATION / LIFTING

VEHICLES WITH AIR DEFLECTOR TYPE 2:

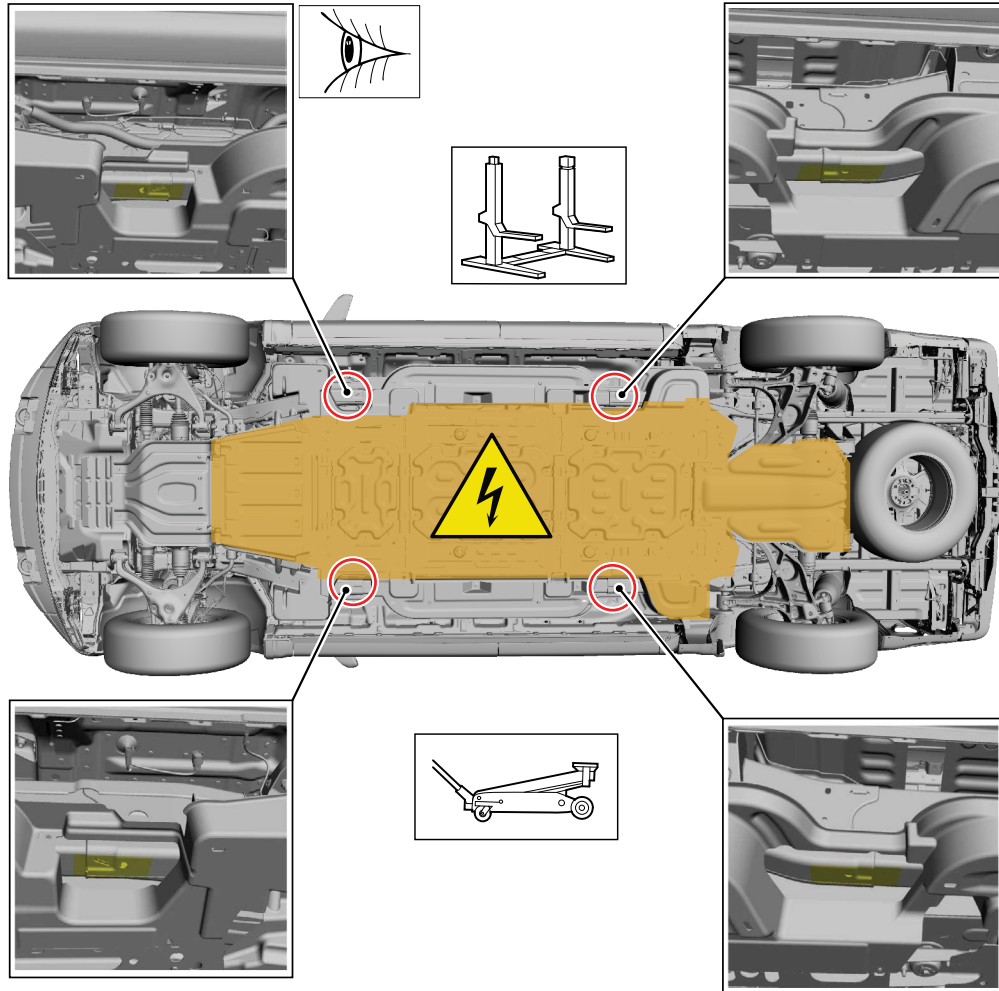

3. Disable direct hazards / safety regulations

HIGH VOLTAGE SYSTEM DISABLE PROCEDURE

IMPORTANT:

- Under urgent situations perform Option 1.
- Under non-urgent situations perform Option 2.

OPTION 1 - Under urgent situations ONLY

1. Open the hood and locate the Low Voltage Service Disconnect.

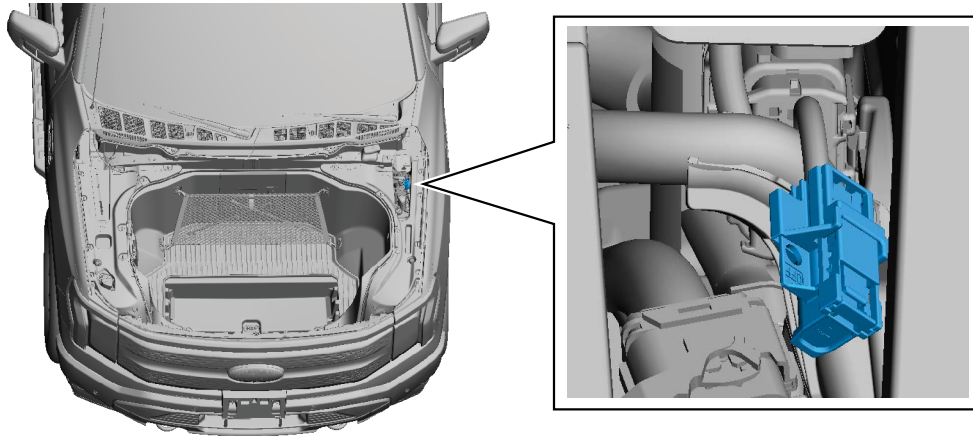

NOTE: If using a larger cutting tool, turn the hand screws to unlock and remove trim panel shown below.

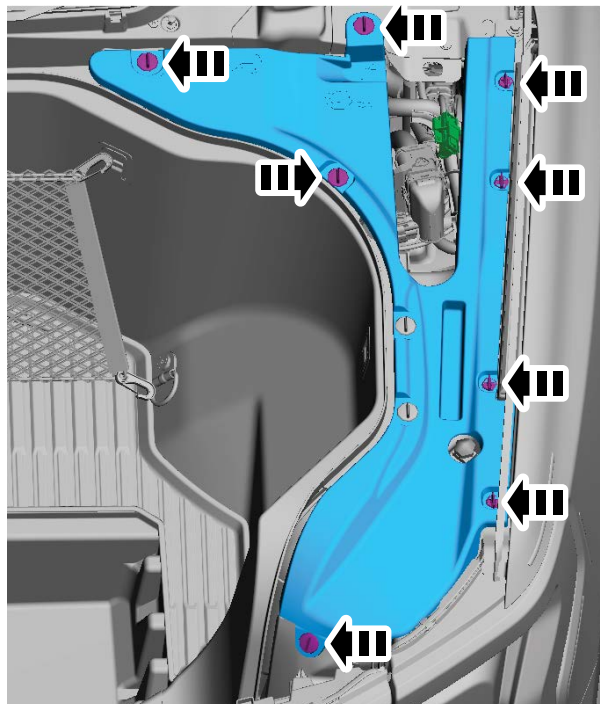

2. Cut the wires and remove the Low Voltage Service Disconnect. Isolate the wires to prevent reconnection.

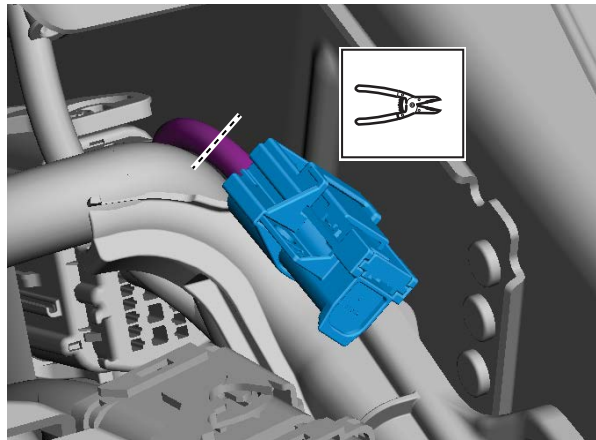

OPTION 2 - Under non-urgent situations

1. Ensure the vehicle transmission gear selector is in the PARK position. Check that the vehicle READY light is off to verify the high voltage system is disconnected. If the vehicle READY light is on, press the engine Start/Stop button to turn off the ignition.



Ensure that the Pro Power Onboard (PPO) System, if equipped, has been deactivated by following the steps below:

2. Vehicle must be powered down for AT LEAST 60 seconds before continuing the procedure.
3. Locate the 3 outlet locations on the vehicle. The outlets are in the frunk, cabin, and truck bed.



4. Verify that the PPO System is deactivated by checking that the LED indicators are deluminated.
5. If the PPO system is still active, press the PPO hard button in EITHER the bed OR the frunk of the vehicle. Pressing either button will deactivate the entire PPO system.
6. Wait at least 60 seconds for PPO system to be depowered.

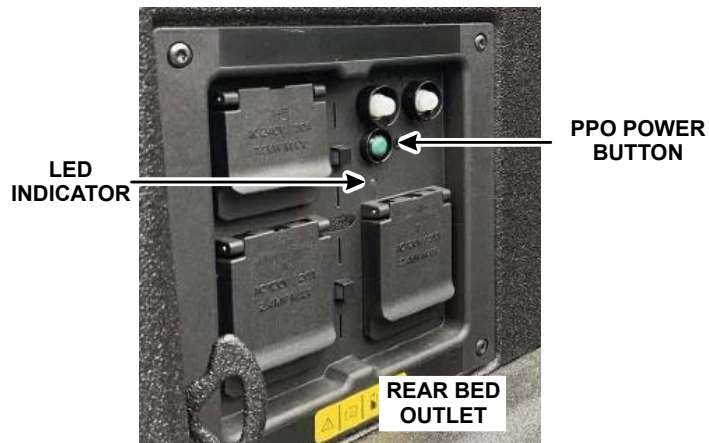
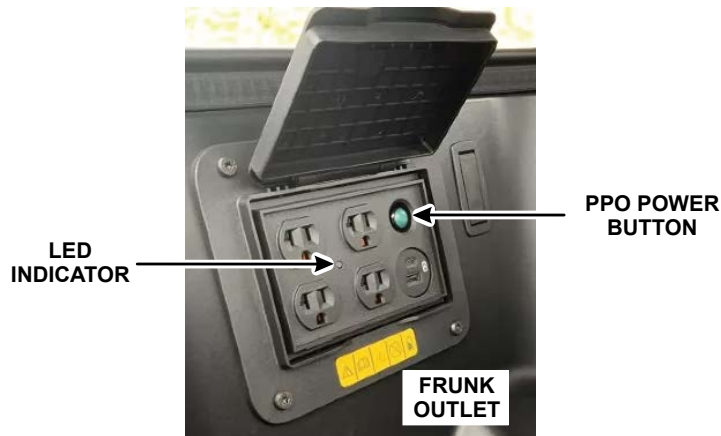
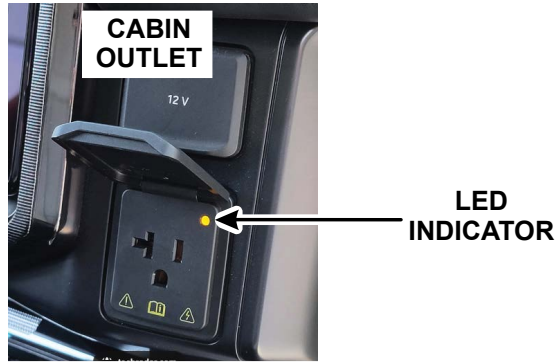

Low Voltage Service Disconnect (Disables High Voltage System)

7. Open the hood.

8. Release the Connector Position Assurance (CPA) clip.

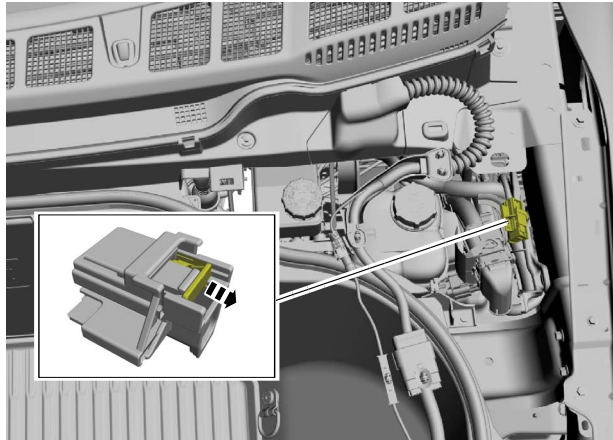

9. **NOTE:** The tab must be depressed prior to pushing the connector back in or damage to the connector may result.

Depress the tab while pulling the connector until the hole is completely visible on the top of the connector.

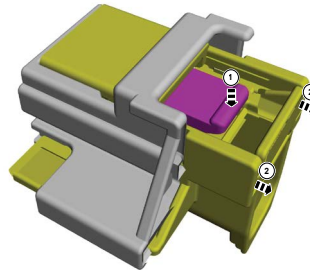

10. Insert a suitable tool inside the connector hole to prevent the connector from closing.



11. Wait a minimum of 5 minutes.



4. Access to the occupants

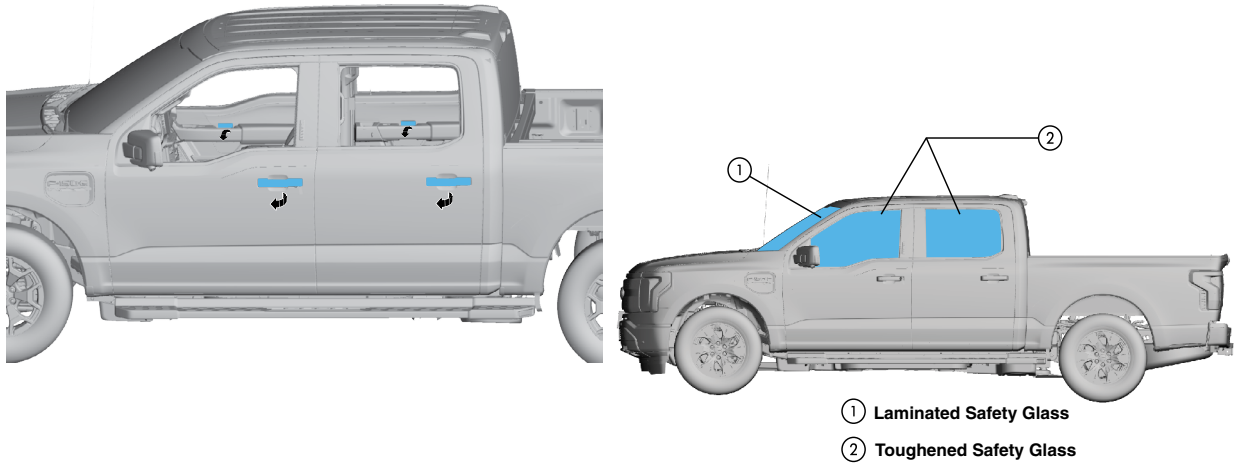

5. Stored energy / liquids / gases / solids



Refer to the vehicle overview illustration on Page 1 for location reference of the high voltage battery, 12V battery, gas tank, and other vehicle component locations.

6. In case of fire



If the vehicle is on fire, use a Class ABC powder-type extinguisher to contain and smother the flames. If water is being used, LARGE amounts of water is required to extinguish the flames. A fire-hydrant or dedicated fire hose can supply the needed amount. Water can cause some degree of arcing/shorting across the cell and/or battery terminals; it can also react with the electrolyte from the cells to generate additional combustible gas and other byproducts such as hydrofluoric acid. However, the cooling and smothering effects of flushing the affected article with large amounts of water and/or other fire suppression material is still beneficial for minimizing the severity of the event.

7. In case of submersion

If the vehicle is submerged in water, varying degrees of arcing/shorting within the battery will take place. Do not touch any High Voltage components or orange cables while removing the occupant(s). Do not remove the vehicle until you are sure the High Voltage battery is completely discharged. A submerged High Voltage battery may produce a fizzing or bubbling reaction to the water. If fizzing or bubbling is observed, the High Voltage battery will be discharged when the fizzing or bubbling has completely stopped. The battery should still be treated as if it is not discharged.

Battery Electric and Hybrid vehicles when submerged should only be handled while wearing the appropriate Personal Protective Equipment (PPE) for water rescue and vehicle extraction.

8. Towing / transportation / storage

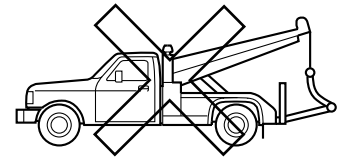
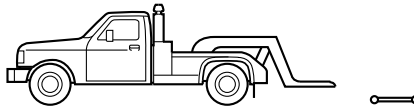
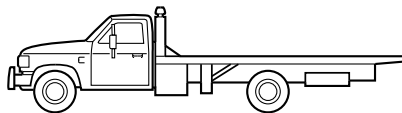
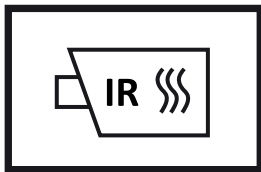

NOTICE: Do not attempt to pull / tow vehicle with wheels on the ground as this may cause the vehicle to generate electricity and can cause potential damage.

NOTE: Front-wheel and rear-wheel drive vehicles must have their designated drive wheels off the ground. Use tow dollies to prevent damage to the transmission.

NOTE: All-wheel or four-wheel drive vehicles require that all wheels be off the ground using a wheel lift and dollies or flatbed equipment.



9. Important additional information

For specific information and safety preparation regarding the High Voltage system, refer to: <https://www.motorcraftservice.com>, select quick guides for the appropriate vehicle emergency response guide.

For First Responder Resources, refer to <https://www.ford.com/firstresponder/>

© Copyright 2024, Ford Motor Company. All rights reserved. This document may be reproduced in its entirety and distributed for emergency responder use only. It may not be excerpted for any purpose.

10. Explanation of pictograms used



Flammable



Explosive



Corrosives



Hazardous
to the
human health



Environmental
hazard



Use water
to extinguish
the fire



Use ABC
powder to
extinguish
the fire



General
warning



Warning,
Electricity



Use infrared thermometer /
Thermal Infrared camera

